

ODM ▶150

24. Apr 2023

DATA SHEET

The **OmniDriveModules** enable customers to create their own omnidirectional robot platforms with minimal effort and within a very short time.

Each module features two independent servo drives. The wheel can turn to face into any direction, allowing a mobile robot to move omnidirectionally. It is even possible to change the robots orientation while driving, which is essential for complex handling and coordination tasks.



The **OmniDriveModules** have already proven themselves very successful in several service robotics applications, especially in unstructured and narrow environments.

Their compact design makes it easy to build unique robots for demanding applications. Thanks to the modules' high power at a small space it is possible to design elegant and slim robots with impressive manoeuvrability and high payload.

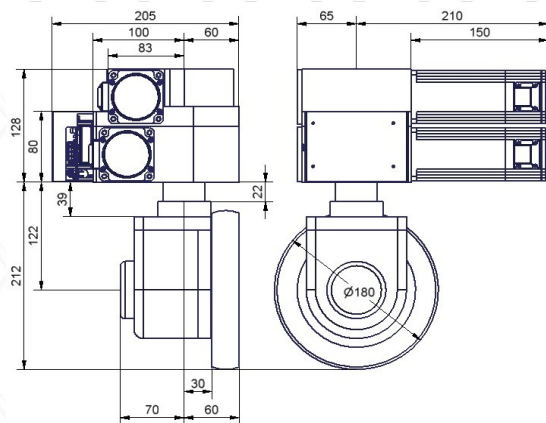

- ▶ **PAYLOAD**
150 kg
- ▶ **WEIGHT**
17 kg
- ▶ **SPEED**
< 0.9 m/s
- ▶ **MOTOR POWER**
2 x 400 W

- ▶ **MOTOR VOLTAGE**
48 VDC
- ▶ **AUXILLARY VOLTAGE**
24 VDC
- ▶ **COMMUNICATION**
CANopen,
RS-232